

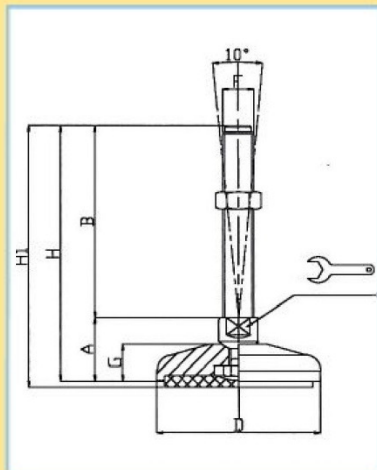

**STAINLESS STEEL BASE (80mm/3.15in)
WITH ARTICULATED STAINLESS STEEL SCREW 10°
- HEAVY LOADS -**





| CODE | | Description | MAIN DIMENSIONS | | | | | | | | STATIC LOAD Lbs |
|----------|----------|-------------|-----------------|-----|----|---|-----|----|-----|-----|--------------------|
| Standard | Antislip | | A | B | D |  | F | G | H | H1 | |
| 11334 | 11335 | M16X100 | 33 | 100 | 80 | 20 | M16 | 19 | 133 | 136 | 6740 |
| 11338 | 11339 | M16X150 | 33 | 150 | 80 | 20 | M16 | 19 | 183 | 186 | 6740 |
| 11342 | 11343 | M16X200 | 33 | 200 | 80 | 20 | M16 | 19 | 233 | 236 | 6740 |
| 11334/20 | 11335/20 | M20X100 | 33 | 100 | 80 | 20 | M20 | 19 | 133 | 136 | 7865 |
| 11338/20 | 11339/20 | M20X150 | 33 | 150 | 80 | 20 | M20 | 19 | 183 | 186 | 7865 |
| 11342/20 | 11343/20 | M20X200 | 33 | 200 | 80 | 20 | M20 | 19 | 233 | 236 | 7865 |
| 11344/20 | 11345/20 | M20X225 | 33 | 225 | 80 | 20 | M20 | 19 | 258 | 261 | 7865 |
| 11334/24 | 11335/24 | M24X100 | 33 | 100 | 80 | 20 | M24 | 19 | 133 | 136 | 8990 |
| 11338/24 | 11339/24 | M24X150 | 33 | 150 | 80 | 20 | M24 | 19 | 183 | 186 | 8990 |
| 11342/24 | 11343/24 | M24X200 | 33 | 200 | 80 | 20 | M24 | 19 | 233 | 236 | 8990 |
| 11344/24 | 11345/24 | M24X225 | 33 | 225 | 80 | 20 | M24 | 19 | 258 | 261 | 8990 |

Stainless steel base AISI 304 (AISI 316 available upon request). Antislip mounts are available with NBR rubber 70 shore. Stainless steel screw AISI 304 (AISI 316 available upon request). The leveling element can be supplied, on request, with steel nut.

Load values mentioned above refer to static conditions calculated at half of the screw length. In conditions of vibrations or in presence of dynamic loads these values should be reduced. We cannot accept responsibility for mounts that have been tampered or modified.

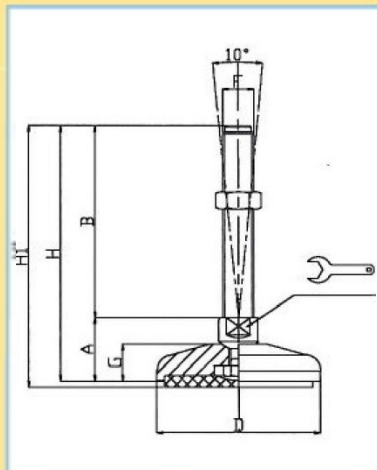
**STAINLESS STEEL BASE (100mm/3.94in)
WITH ARTICULATED STAINLESS STEEL SCREW 10°
- HEAVY LOADS -**





| CODE | | Description | MAIN DIMENSIONS | | | | | | | | STATIC LOAD Lbs |
|----------|----------|-------------|-----------------|-----|-----|---|-----|----|-----|-----|--------------------|
| Standard | Antislip | | A | B | D |  | F | G | H | H1 | |
| 11382 | 11383 | M20X100 | 34 | 100 | 100 | 20 | M20 | 20 | 134 | 137 | 8990 |
| 11386 | 11387 | M20X150 | 34 | 150 | 100 | 20 | M20 | 20 | 184 | 187 | 8990 |
| 11390 | 11391 | M20X200 | 34 | 200 | 100 | 20 | M20 | 20 | 234 | 237 | 8990 |
| 11392 | 11393 | M20X225 | 34 | 225 | 100 | 20 | M20 | 20 | 259 | 262 | 8990 |
| 11382/24 | 11383/24 | M24X100 | 34 | 100 | 100 | 20 | M24 | 20 | 134 | 137 | 10,115 |
| 11386/24 | 11387/24 | M24X150 | 34 | 150 | 100 | 20 | M24 | 20 | 184 | 187 | 10,115 |
| 11390/24 | 11391/24 | M24X200 | 34 | 200 | 100 | 20 | M24 | 20 | 234 | 237 | 10,115 |
| 11392/24 | 11393/24 | M24X225 | 34 | 225 | 100 | 20 | M24 | 20 | 259 | 262 | 10,115 |
| 11382/30 | 11383/30 | M30X100 | 40 | 100 | 100 | 26 | M30 | 20 | 140 | 143 | 11,240 |
| 11386/30 | 11387/30 | M30X150 | 40 | 150 | 100 | 26 | M30 | 20 | 190 | 193 | 11,240 |
| 11390/30 | 11391/30 | M30X200 | 40 | 200 | 100 | 26 | M30 | 20 | 240 | 243 | 11,240 |
| 11392/30 | 11393/30 | M30X225 | 40 | 225 | 100 | 26 | M30 | 20 | 265 | 268 | 11,240 |

Stainless steel base AISI 304 (AISI 316 available upon request). Antislip mounts are available with NBR rubber 70 shore. Stainless steel screw AISI 304 (AISI 316 available upon request). The leveling element can be supplied, on request, with steel nut.

Load values mentioned above refer to static conditions calculated at half of the screw length. In conditions of vibrations or in presence of dynamic loads these values should be reduced. We cannot accept responsibility for mounts that have been tampered or modified.

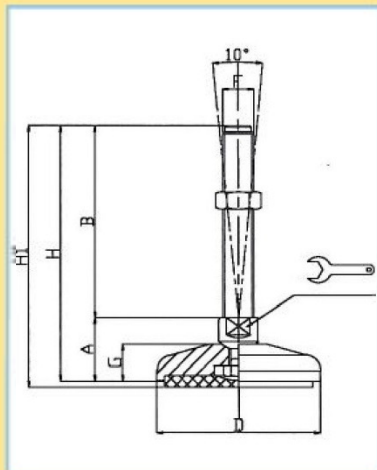
**STAINLESS STEEL BASE (120mm/4.7in)
WITH ARTICULATED STAINLESS STEEL SCREW 10°
- HEAVY LOADS -**





| CODE | | Description | MAIN DIMENSIONS | | | | | | | | STATIC LOAD Lbs |
|----------|----------|-------------|-----------------|-----|-----|---|-----|----|-----|-----|--------------------|
| Standard | Antislip | | A | B | D |  | F | G | H | H1 | |
| 11430 | 11431 | M20X100 | 36 | 100 | 120 | 20 | M20 | 22 | 136 | 139 | 10,115 |
| 11434 | 11435 | M20X150 | 36 | 150 | 120 | 20 | M20 | 22 | 186 | 189 | 10,115 |
| 11438 | 11439 | M20X200 | 36 | 200 | 120 | 20 | M20 | 22 | 236 | 239 | 10,115 |
| 11440 | 11441 | M20X225 | 36 | 225 | 120 | 20 | M20 | 22 | 261 | 264 | 10,115 |
| 11430/24 | 11431/24 | M24X100 | 36 | 100 | 120 | 20 | M24 | 22 | 136 | 139 | 11,240 |
| 11434/24 | 11435/24 | M24X150 | 36 | 150 | 120 | 20 | M24 | 22 | 186 | 189 | 11,240 |
| 11438/24 | 11439/24 | M24X200 | 36 | 200 | 120 | 20 | M24 | 22 | 236 | 239 | 11,240 |
| 11440/24 | 11441/24 | M24X225 | 36 | 225 | 120 | 20 | M24 | 22 | 261 | 264 | 11,240 |
| 11430/30 | 11431/30 | M30X100 | 42 | 100 | 120 | 26 | M30 | 22 | 142 | 145 | 13,485 |
| 11434/30 | 11435/30 | M30X150 | 42 | 150 | 120 | 26 | M30 | 22 | 192 | 195 | 13,485 |
| 11438/30 | 11439/30 | M30X200 | 42 | 200 | 120 | 26 | M30 | 22 | 242 | 275 | 13,485 |
| 11440/30 | 11441/30 | M30X225 | 42 | 225 | 120 | 26 | M30 | 22 | 267 | 270 | 13,485 |

Stainless steel base AISI 304 (AISI 316 available upon request). Antislip mounts are available with NBR rubber 70 shore. Stainless steel screw AISI 304 (AISI 316 available upon request). The leveling element can be supplied, on request, with steel nut.

Load values mentioned above refer to static conditions calculated at half of the screw length. In conditions of vibrations or in presence of dynamic loads these values should be reduced. We cannot accept responsibility for mounts that have been tampered or modified.

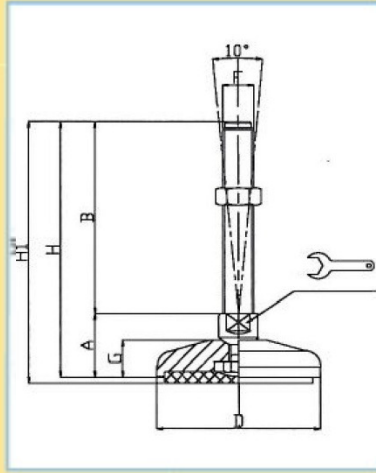
**STAINLESS STEEL BASE (159mm/6.25in)
WITH ARTICULATED STAINLESS STEEL SCREW 10°
- HEAVY LOADS -**



| CODE | | Description | MAIN DIMENSIONS | | | | | | | | STATIC LOAD Lbs |
|----------|----------|-------------|-----------------|-----|-----|---|-----|----|-----|-----|--------------------|
| Standard | Antislip | | A | B | D |  | F | G | H | H1 | |
| 11478 | 11479 | M20X100 | 37 | 100 | 159 | 20 | M20 | 23 | 137 | 140 | 11,240 |
| 11482 | 11483 | M20X150 | 37 | 150 | 159 | 20 | M20 | 23 | 187 | 190 | 11,240 |
| 11486 | 11487 | M20X200 | 37 | 200 | 159 | 20 | M20 | 23 | 237 | 240 | 11,240 |
| 11488 | 11489 | M20X225 | 37 | 225 | 159 | 20 | M20 | 23 | 262 | 265 | 11,240 |
| 11478/24 | 11479/24 | M24X100 | 38 | 100 | 159 | 20 | M24 | 23 | 138 | 141 | 13,485 |
| 11482/24 | 11483/24 | M24X150 | 38 | 150 | 159 | 20 | M24 | 23 | 188 | 191 | 13,485 |
| 11486/24 | 11487/24 | M24X200 | 38 | 200 | 159 | 20 | M24 | 23 | 238 | 241 | 13,485 |
| 11488/24 | 11489/24 | M24X225 | 38 | 225 | 159 | 20 | M24 | 23 | 263 | 266 | 13,485 |
| 11478/30 | 11479/30 | M30X100 | 42 | 100 | 159 | 26 | M30 | 23 | 142 | 145 | 15,735 |
| 11482/30 | 11483/30 | M30X150 | 42 | 150 | 159 | 26 | M30 | 23 | 192 | 195 | 15,735 |
| 11486/30 | 11487/30 | M30X200 | 42 | 200 | 159 | 26 | M30 | 23 | 242 | 245 | 15,735 |
| 11488/30 | 11489/30 | M30X225 | 42 | 225 | 159 | 26 | M30 | 23 | 267 | 270 | 15,735 |

Stainless steel base AISI 304 (AISI 316 available upon request). Antislip mounts are available with NBR rubber 70 shore. Stainless steel screw AISI 304 (AISI 316 available upon request). The leveling element can be supplied, on request, with steel nut.

Load values mentioned above refer to static conditions calculated at half of the screw length. In conditions of vibrations or in presence of dynamic loads these values should be reduced. We cannot accept responsibility for mounts that have been tampered or modified.